

PRODUCT SPECIFICATION

产品规范

适用于 For
QD302 数传模块
QD302 Datalink Module



INTRODUCTION

REVISION HISTORY / 修订历史

Revision/版本	Modification/更改	Date/日期
1.0	New Release / 新发	2023/09/22
1.1	Add Receiving Sensitivity / 添加接收灵敏度	2023/09/25
1.2	Change Weight / 更改重量	2023/10/18
1.3	Add CE and FCC Certification / 增加CE、FCC认证	2024/01/17

DIRETORY / 目录

REVISION HISTORY / 修订历史.....	2
DIRETORY / 目录.....	3
1. Introduction / 简介.....	4
1.1. Product Characteristics / 产品特性.....	4
2. Certification / 认证.....	8
3. QD302 Product Size / QD302 尺寸.....	9
4. Pin Arrangement and Definition / 针脚标识和定义.....	10
4.1. Remarks / 说明.....	11
5. Assembling & Repairing Note / 装配及维修说明.....	14
5.1. Module Assembling Note / 模块装配说明.....	14
5.2. Repairing Note / 维修说明.....	15
6. Application Connection Example / 应用连接示例.....	16
6.1. TTL to RS232 application circuit / TTL转RS232应用电路.....	16
6.2. Recommended power supply circuit design / 推荐电源供电电路设计.....	17
6.3. Reserve external antenna ports / 预留外部天线接口.....	18
6.4. Signal indicating and reset circuit / 信号指示和复位电路.....	18
7. Packaging Information / 包装信息.....	20
Figures	
Figure 1. QD302 CE and FCC Certification / QD302 CE、FCC认证.....	8
Figure 2. QD302 Product Photo / QD302 实物图.....	9
Figure 3. QD302 Dimension View / QD302 三视图.....	9
Figure 4. QD302 Includes 32-Pin Pad / QD302 包括32连接焊盘.....	10
Figure 5. Furnace Temperature Curve / 炉温曲线.....	14
Figure 6. Connections between RS232 COM1, 2 of QD302 and Some Other Devices with an UART / QD302 RS232 COM1、2与其他使用UART接口的设备之间的连接示意图.....	16
Figure 7. Connection of QD302 COM Connector to PC / QD302 COM与电脑连接原理图.....	17
Figure 8. QD302 Power Supply Design Circuit Diagram / QD302供电设计电路示意图.....	17
Figure 9. QD302 External Antenna Connection Circuit Diagram / QD302外部天线连接电路示意图.....	18
Figure 10. Schematic diagram of QD302 signal indicating circuit / QD302信号指示电路示意图.....	18
Figure 11. QD302 Reset circuit diagram / QD302复位电路示意图.....	19
Figure 12. QD302 Roll Tape Packing / QD302卷带包装.....	20
Tables	
Table 1. Product Characteristics / 产品特性.....	4
Table 2. Pin Definition of QD302 32-Pin Pad / QD302 32针脚焊盘的针脚定义.....	10
Table 3. LVCMOS 3.3V Electrical Standard / LVCMOS 3.3V电气标准.....	11
Table 4. LVTTTL 3.3V Electrical Standard / LVTTTL 3.3V电气标准.....	12
Table 5. QD302 Package Description / QD302包装说明.....	20

1. Introduction / 简介

QD302 is a high performance wireless datalink module that specially designed for GNSS differential data transmission by QeeTek Technology Ltd. The advanced technology of using advanced CSS digital modulation and demodulation technology, integrating receiving and transmitting functions make it suitable for RTK real time data transmission. It has the advantage of stable output power, high receiving sensitivity, low error rate and strong anti-interference ability. Besides, its characteristics of small size, low power consumption, better electromagnetic compatibility, pin type interface, and modular design are in favor of system integration.

QD302数传模块是软天电子专为GNSS差分数据传输设计的高性能数传模块，采用先进的CSS数字调制解调技术，集接收和发射功能于一体，适用于RTK实时数据传输；并具有输出功率稳定、接收灵敏度高、低误码率、抗干扰能力强等优点，确保恶劣环境下能正常工作。它体积小、功耗低、电磁兼容性好、贴片式接口设计、模块化设计，便于各种系统集成。

1.1. Product Characteristics / 产品特性

Table 1. Product Characteristics / 产品特性

Characteristics	QD302
Channel Spacing 信道间隔	125 KHz / 250 KHz / 500 KHz
Work Pattern 工作模式	Half Duplex 半双工
Working Frequency 工作频率	EU: 863 MHz ~ 870 MHz US: 902 MHz ~ 928 MHz
Modulation System 调制方式	CSS
Air Baud Rate 空中波特率	500 / 11000 / 12500 / 15500 / 18000 bps / 自定义
Protocol Type 协议类型	LoRa

©2024, QeeTek Technology Ltd. All rights reserved. QeeTek is the trade mark of QeeTek Technology Ltd, registered in People's Republic of China. All other trademarks are the property of their respective owners.

Functional Characteristics 功能特性*	Two-way Communication 双向通信	The default mode of the set data transmission modules is "receiving mode", the serial port receives data or the data buffer filled is switched to the transmitting mode; when the data transmission is completed, it will be restored to the receiving mode. 一组数传模块默认接收模式，串口接收数据或数据buffer填充切换至发射模式；数据发送完成恢复至接收模式。
	SN Number Binding SN号绑定	The SN number of the receiver and sender correspond one by one, and the mobile station judges the SN number after receiving the base station data. 接收端与发送端的SN号一一对应，移动站收到基站数据后进行SN号判断。
	Interference Monitoring 干扰监测	When it is initialization and signal data quality is poor, it triggers detection. The current default configuration is ten channel detection, each channel detection threshold is -60dBm, and the detection time is 1000ms. 初始化和信号数据质量差触发检测，当前默认配置十个信道检测，每个信道检测阈值-60dBm，检测时间1000ms。
	Adaptive Frequency Switching 自适应频率切换	If there is interference during work, then this function will take effect after the self-test is triggered, aligning the working channel/frequency of the base station and mobile station, it switches the working channel to a non-interference frequency. 工作过程中有干扰，触发自检后生效，对齐基站移动站工作信道/频点，将工作信道切换至无干扰频率。

©2024, QeeTek Technology Ltd. All rights reserved. QeeTek is the trade mark of QeeTek Technology Ltd, registered in People's Republic of China. All other trademarks are the property of their respective owners.

	Waking up And Sleeping 唤醒与休眠	Through the command suspend, the remote control base station enters a sleep state to save power consumption. 通过指令suspend, 远程控制基站进入休眠状态, 以节省功耗。
	Working Status Indication 工作状态指示	PIN31 and PIN32 are the status indication GPIO ports, 11 indicates busy, and 00 indicates idle. PIN31 与 PIN32 为状态指示GPIO口, 11 指示 busy, 00 指示idle。
Serial Port Baud Rate 串口波特率	4800 bps / 9600 bps / 19200 bps / 38400 bps / 115200 bps	
Electrical Characteristics 电气特性	Power supply range 供电范围	+3.3 V ~ +3.6 V DC
	Receive Power 接收功耗	0.17 W ~ 0.18 W
	Receiving Sensitivity 接收灵敏度	-129dBm, transmission distance up to 2km (open environment, no obstacle interference, maximum power, altitude 2m, air baud rate 2.4kbps) -129dBm, 传输距离可达 2km (空旷环境、无障碍物干扰、最大功率、高度 2m、空中波特率 2.4kbps)
	Transmit Power 发射功耗	0.18 W ~ 0.5 W
	Transmit Signal Power 发射信号功率	(14±1) dBm / (17±1) dBm / (20±1) dBm EU:(14±1) dBm US:(20±1) dBm

©2024, QeeTek Technology Ltd. All rights reserved. QeeTek is the trade mark of QeeTek Technology Ltd, registered in People's Republic of China. All other trademarks are the property of their respective owners.

Physical Characteristics 物理特性	Communication Interface 通讯接口	2x16 Pin Pin Pitch 1.27 mm (引脚间距 1.27 mm)
	Antenna Interface 天线接口	IPEX-J
	Antenna Gain 天线增益	4 dBi
	Size (With Connectors) 尺寸(含接头)	22 mm x17 mm x3.2 mm
	Weight 重量	2.2 g
Environmental Characteristics 环境特性	Working Temperature 工作温度	-40 °C ~ +85 °C
	Storage Temperature 存储温度	-45 °C ~ +85 °C

©2024, QeeTek Technology Ltd. All rights reserved. QeeTek is the trade mark of QeeTek Technology Ltd. registered in People's Republic of China. All other trademarks are the property of their respective owners.

2. Certification / 认证

This section provides a picture of the certification certificate of QD302, which complies with CE and FCC standards.

本节提供了QD302的认证证书图片，符合CE、FCC规格。



Figure 1. QD302 CE and FCC Certification / QD302 CE、FCC认证

3. QD302 Product Size / QD302 尺寸

In this section, product photo, three-side views and the dimension of QD302 is provided for customers' further hardware design and installation.

本节提供了QD302的实物图，三视图和对应的物理尺寸，便于用户进一步系统硬件设计和安装。



Figure 2. QD302 Product Photo / QD302 实物图

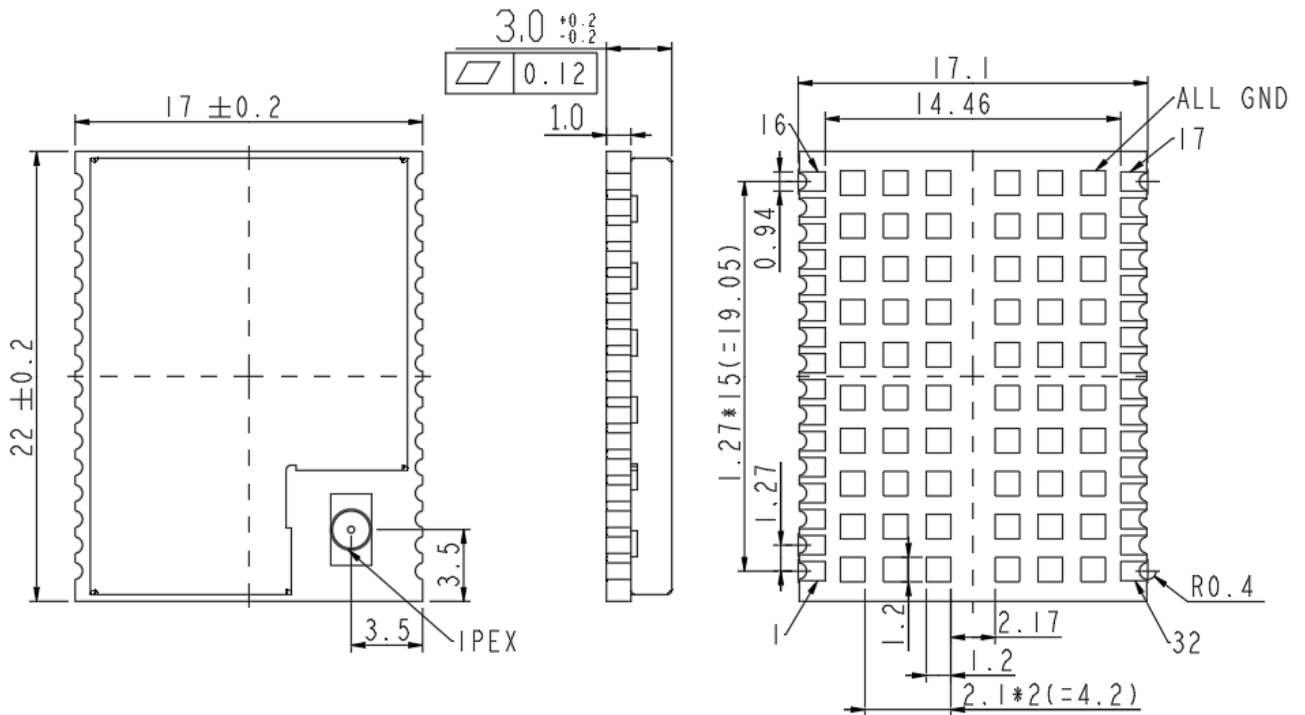

Figure 3. QD302 Dimension View / QD302 三视图

©2024, QeeTek Technology Ltd. All rights reserved. QeeTek is the trademark of QeeTek Technology Ltd, registered in People's Republic of China. All other trademarks are the property of their respective owners.

4. Pin Arrangement and Definition / 针脚标识和定义

QD302 is surface-mount OEM Module which integrates 32 Pin (pitch 1.27mm).

QD302包括32Pin, 表贴式模块 (pitch 1.27mm)。

1	GND	GND	32
2	ANT	STATUS_FLAG	31
3	GND	STATUS_FLAG	30
4	RES	GND	29
5	RES	RES	28
6	GND	RES	27
7	RES	GND	26
8	RES	UART2_TX	25
9	RES	UART2_RX	24
10	RES	GND	23
11	GND	T/RX_FLAG	22
12	UART1_RX	SYS_FLAG	21
13	UART1_TX	GND	20
14	RES	GND	19
15	RSTN	VCC	18
16	GND	VCC	17

Figure 4. QD302 Includes 32-Pin Pad / QD302 包括32连接焊盘

Table 2. Pin Definition of QD302 32-Pin Pad / QD302 32针脚焊盘的针脚定义

PIN	SIGNAL	TYPE	DESCRIPTION	
1	GND	GND	Ground Reference	系统接地
2	ANT	I/O	ANT_Input/Output	天线输入/输出
3	GND	GND	Ground Reference	系统接地
4~5	RES	I/O	General-purpose input/output	通用输入输出 (悬空)
6	GND	GND	Ground Reference	系统接地
7~10	RES	I/O	General-purpose input/output	通用输入输出 (悬空)
11	GND	GND	Ground Reference	系统接地
12	UART1_RX	I	UART1_RX	串口1输入
13	UART1_TX	O	UART1_TX	串口1输出

©2024, QeeTek Technology Ltd. All rights reserved. QeeTek is the trade mark of QeeTek Technology Ltd. registered in People's Republic of China. All other trademarks are the property of their respective owners.

PIN	SIGNAL	TYPE	DESCRIPTION	
14	RES	I/O	General-purpose input/output	通用输入输出（悬空）
15	RSTN	I	Quick reset without clearing user configuration	快速复位，不清除用户配置
16	GND	GND	Ground Reference	系统接地
17~18	VCC	PWR	POWER	系统电源
19~20	GND	GND	Ground Reference	系统接地
21	SYS_FLAG	O	SYS_FLAG	系统工作标识
22	T/RX_FLAG	O	T/RX_FLAG	收/发信号标识
23	GND	GND	Ground Reference	系统接地
24	UART2_RX	I	UART2_RX	串口2输入
25	UART2_TX	O	UART2_TX	串口2输出
26	GND	GND	Ground Reference	系统接地
27~28	RES	I/O	General-purpose input/output	通用输入输出
29	GND	GND	Ground Reference	系统接地
30~31	STATUS_FLAG	O	STATUS_FLAG	工作状态标识
32	GND	GND	Ground Reference	系统接地

4.1. Remarks / 说明

1. Electrical Characteristics / 电气特性

UART1/2_TX / RX are LVCMOS 3.3V electrical standard.

UART1/2_TX/RX为LVCMOS 3.3V电气标准。

Table 3. LVCMOS 3.3V Electrical Standard / LVCMOS 3.3V电气标准

Symbols 符号	Description 描述	Min 最小	Max 最大
V _{IH}	Input high voltage 输入高电压	2.0V	VCC+0.3V
V _{IL}	Input low voltage 输入低电压	-0.3V	0.8V
V _{OH}	High-level output voltage 高电平输出电压	VCC-0.4V	--
V _{OL}	Low-level output voltage 低电平输出电压	--	0.41V
I _{OH}	Sourcing current 拉电流		8mA
I _{OL}	Sinking current 灌电流		8mA

©2024, QeeTek Technology Ltd. All rights reserved. QeeTek is the trademark of QeeTek Technology Ltd. registered in People's Republic of China. All other trademarks are the property of their respective owners.

Table 4. LVTTTL 3.3V Electrical Standard / LVTTTL 3.3V电气标准

Symbols 符号	Description 描述	Min 最小	Max 最大
V_{IH}	Input high voltage 输入高电压	2.0V	$V_{CC}+0.3V$
V_{IL}	Input low voltage 输入低电压	-0.3V	0.8V
V_{OH}	High-level output voltage 高电平输出电压	$V_{CC}-0.4V$	--
V_{OL}	Low-level output voltage 低电平输出电压	--	0.41V
I_{OH}	Sourcing current 拉电流		8mA
I_{OL}	Sinking current 灌电流		8mA

2. Can withstand Voltage Range / 能承受的电压范围

The signal with the maximum voltage range from -0.3V to 3.6V is as follows: UART1/2_TX / RX .

所能承受电压的最大值范围是-0.3V~3.6V的信号如下：UART1/2_TX / RX。

3. Supply Voltage / 供电电压

Main power supply (input), voltage range: 3.3V to 3.6V (DC). Voltage ripple and spike demand: <100mV.

主供电电源（输入），电压范围：3.3V~3.6V（直流）。电压纹波和尖峰脉冲需求：<100mV。

4. Precautions for Firmware Upgrade / 固件升级注意事项

QD302 only has two serial ports of UART1 and UART2, but only UART1 supports firmware upgrade.

QD302只有UART1和UART2的两个串口，但是仅UART1支持固件升级。

5. Thermal / 散热

It is recommended that the heat dissipation pad at the bottom of the module be grounded to provide the best heat dissipation of the module.

建议模块底部散热焊盘接地，提高模块散热效果。



5. Assembling & Repairing Note / 装配及维修说明

5.1. Module Assembling Note / 模块装配说明

QD302 is surface mounted, SMT welding is recommended for assembly.

QD302为表贴式模块，推荐使用SMT的焊接方式进行装配。

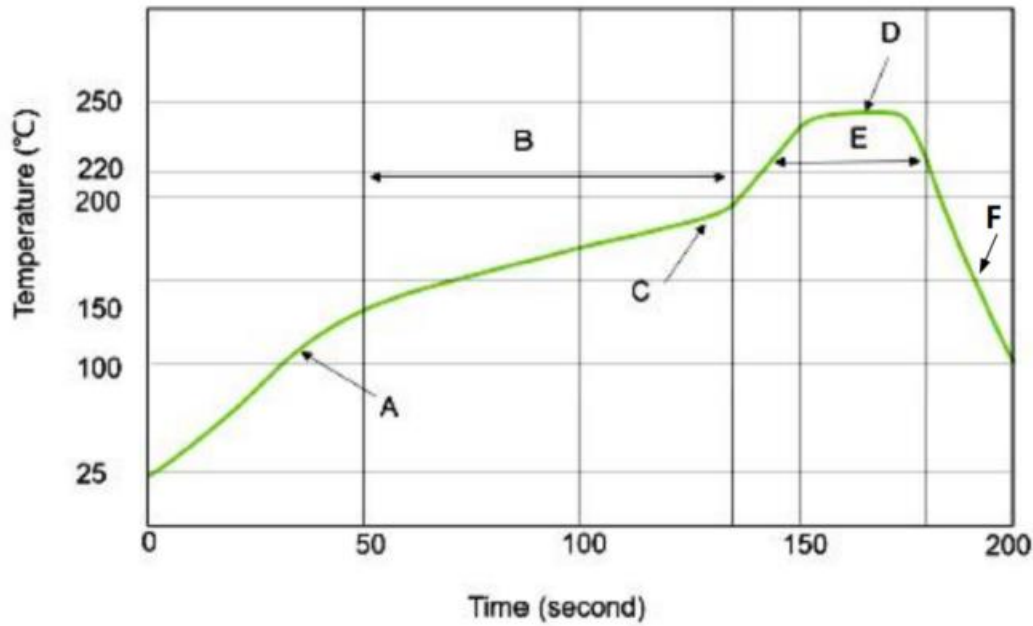

Figure 5. Furnace Temperature Curve / 炉温曲线

The process temperature limits are as follows:

- A: Heating Zone: Rising Slope: 1 ~ 3°C / sec
- B: Constant Temperature Zone: Range: 150 ~ 190 °C Time: 80 ~ 110 S
- C: Constant Temperature→Reflow Zone: Rising Slope: 1 ~ 3°C / sec
- D: Peak Temperature: 235 ~ 245°C
- E: Reflow Zone: Range: Over 220°C Time: 50 ~ 80 S
- F: Descent Slope: -5°C ~ -1°C / sec

制程温度界限如下：

- A: 升温区：斜率：1 ~ 3°C / sec
- B: 恒温区：150 ~ 190°C 时间：80 ~ 110S
- C: 恒温→回流区：斜率：1 ~ 3°C / sec
- D: 峰值温度：235 ~ 245°C
- E: 回流区：大于220°C 时间：50 ~ 80S
- F: 下降斜率：-5 ~ -1°C / sec

In order to prevent the module from being damaged by repeated heating, it is recommended to place the module after finishing the first side of PCB board.

为避免模块因反复受热而损坏，建议在完成PCB板第一面的回流焊之后再贴模块。

5.2. Repairing Note / 维修说明

When disassembling the module, it is suggested using a BGA welding bench. Please use correct air tuyere and choose certain temperature curve. Keep peak temperature under 245°C, rising slope under 3°C /s.

拆卸模块时，请使用BGA返修台，选择适合尺寸的风嘴并使用合适的温度曲线，最高温度不超过245°C，升温斜率不超过3°C/s。

6. Application Connection Example / 应用连接示例

In this section, an application connection example of QD302 OEM Module is presented via specific schematic diagrams. Per the instruction of these diagrams, you could easily build the communication circuits between QD302 OEM Module and other terminals such as PC, GPRS or Bluetooth module, and some other devices with an UART.

本部分以具体电路的形式提供一个QD302模块应用连接示例。参照下面的图示，您可以很方便建立QD302模块和其他终端（如PC，GPRS模块，蓝牙模块或其他带有UART的设备）之间的通讯电路。

6.1. TTL to RS232 application circuit / TTL转RS232应用电路

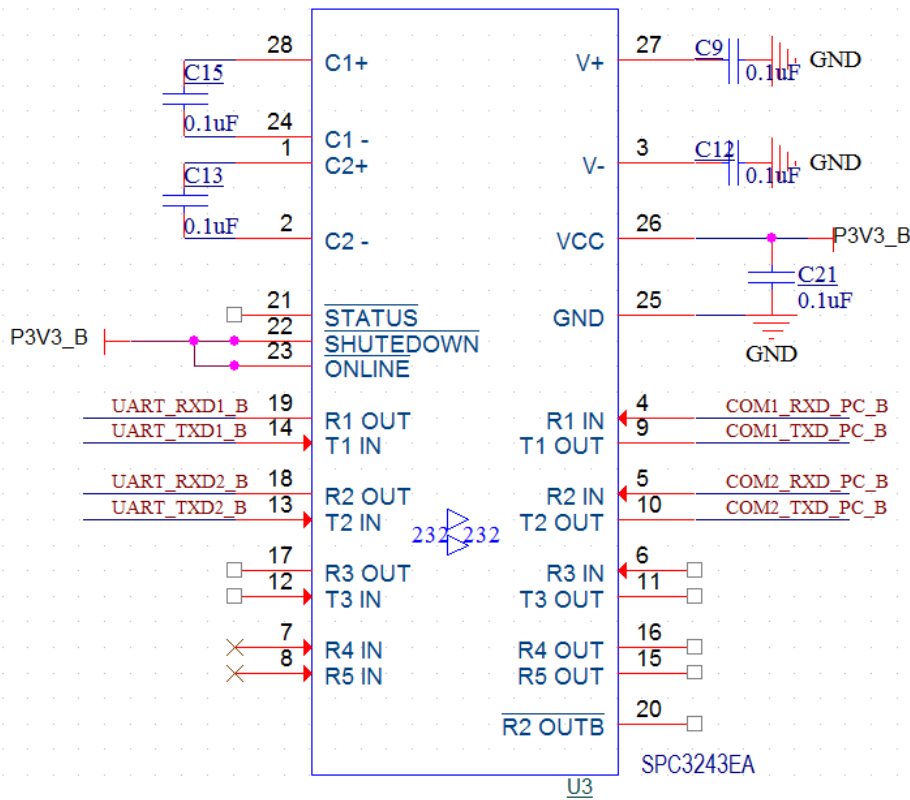

Figure 6. Connections between RS232 COM1, 2 of QD302 and Some Other Devices with an UART / QD302 RS232 COM1、2与其他使用UART接口的设备之间的连接示意图

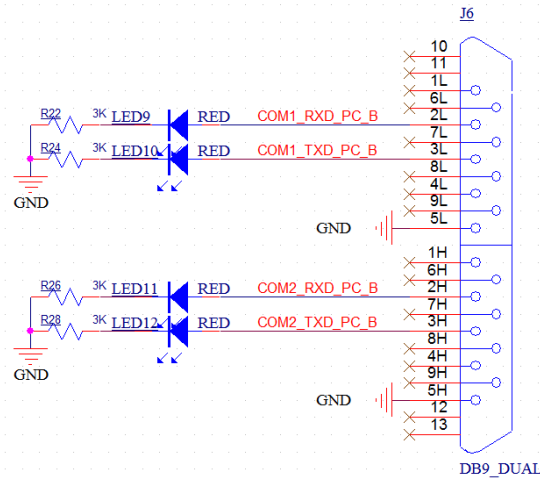

Figure 7. Connection of QD302 COM Connector to PC / QD302 COM与电脑连接原理图

6.2. Recommended power supply circuit design / 推荐电源供电电路设计

In the case of improper EMI adaptation of the DC switching power supply, the receiving performance of the module will be affected. Therefore, it is recommended to add a low-noise LDO circuit or other noise reduction circuit to the output end of the DCDC Vout.

在DCDC开关电源的EMI适配不当情况下，会影响模块的接收性能，建议在DCDC Vout输出端增加低噪声LDO电路或者其它降噪电路。

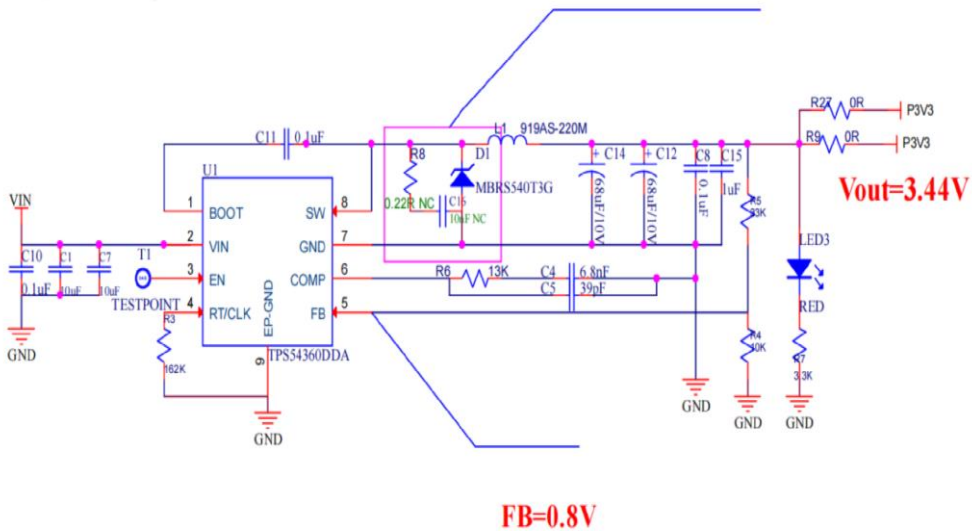

Figure 8. QD302 Power Supply Design Circuit Diagram / QD302供电设计电路示意图

6.3. Reserve external antenna ports / 预留外部天线接口

To use it, remove the ipex interface from the module and weld the 0402 package to the 0 Ω resistance connection signal.

如需使用，需要拆除片上ipex接口，并焊接0402封装0Ω电阻连接信号。

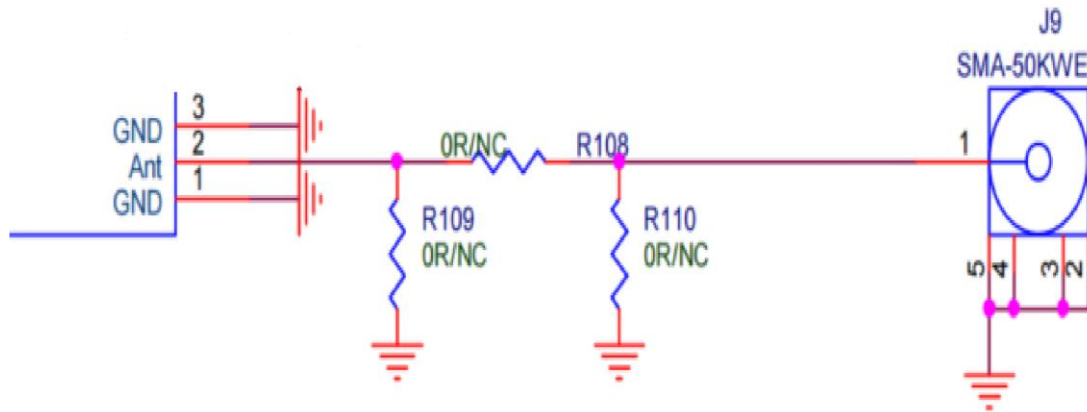

Figure 9. QD302 External Antenna Connection Circuit Diagram / QD302外部天线连接电路示意图

6.4. Signal indicating and reset circuit / 信号指示和复位电路

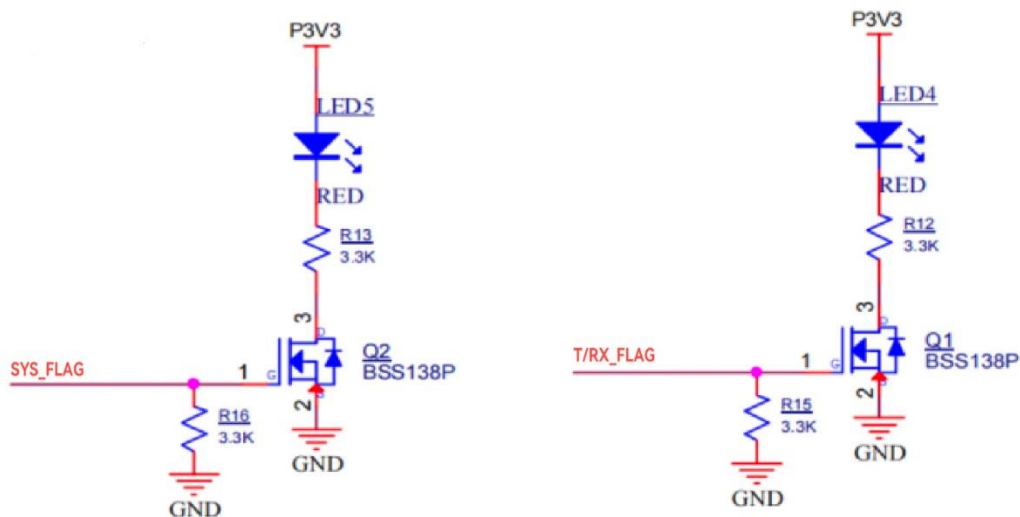

Figure 10. Schematic diagram of QD302 signal indicating circuit / QD302信号指示电路示意图

©2024, QeeTek Technology Ltd. All rights reserved. QeeTek is the trademark of QeeTek Technology Ltd, registered in People's Republic of China. All other trademarks are the property of their respective owners.

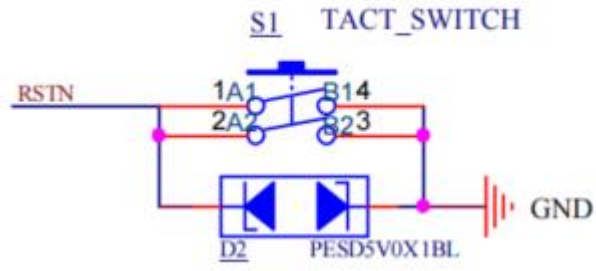

Figure 11. QD302 Reset circuit diagram / QD302复位电路示意图

7. Packaging Information / 包装信息

QD302 module is packaged in a vacuum-sealed aluminum foil electrostatic bag containing desiccant and moisture proof by means of carrier tape and coil (applicable to mainstream surface mount equipment). When welding modules by reflow soldering process, please strictly comply with IPC standards for humidity control of modules. Because the packing materials such as the carrier belt can only withstand 55°C, the modules need to be removed from the packaging during baking operation.

QD302 模块使用载带、卷盘方式（适用于主流表面贴装设备），包装在真空密封的铝箔防静电袋中，内含干燥剂防潮。采用回流焊工艺焊接模块时，请严格遵守IPC标准对模块进行湿度管控。由于载带等包装材料只能承受55°C，在进行烘烤作业时需要将模块从包装中取出。

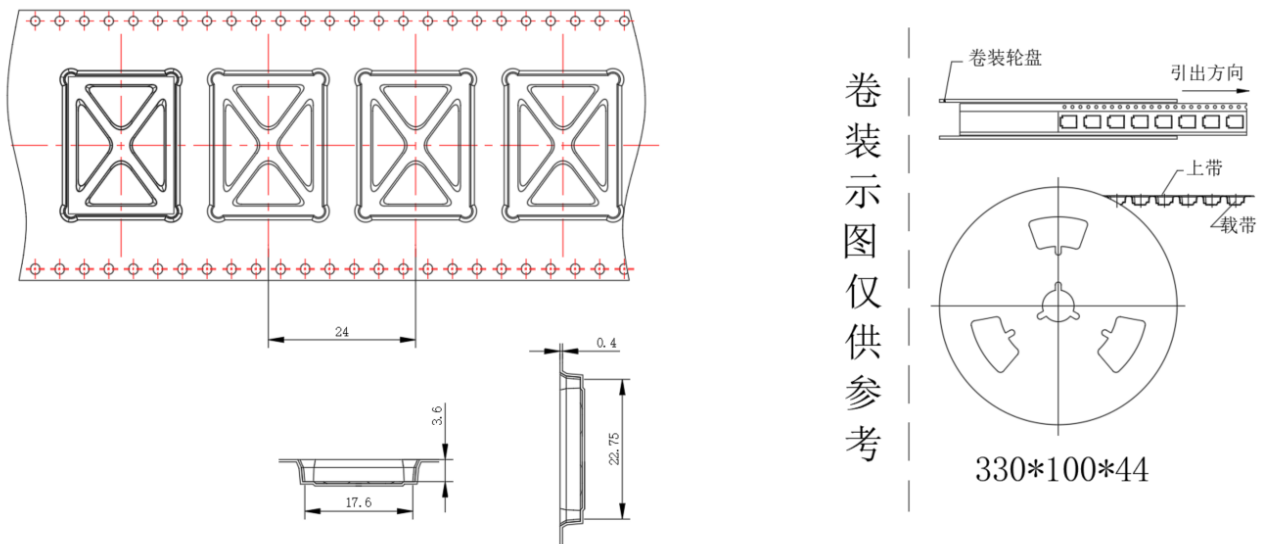

Figure 12. QD302 Roll Tape Packing / QD302卷带包装

Table 5. QD302 Package Description / QD302包装说明

Project	Description
Number of Modules 模块数量	600 Slice/Roll 600片/卷
Reel Size 卷盘尺寸	Material tray:13 inches 料盘: 13寸 Outer diameter: 330mm, inner diameter: 100mm, width: 44mm, wall thickness: 3.6mm

	外径330mm, 内径100mm, 宽44mm, 壁厚3.6mm
	Package of each module: length 22.75mm, width 17.6mm 每个模块包装: 长22.75mm, 宽17.6mm
Carrier Belt 载带	Module Spacing (Center Distance): 24mm 模块间距 (中心距) : 24mm

上海钦天信息技术有限公司

QeeTek Technology, LTD.

上海市嘉定区澄浏中路618号1号楼B区6楼

6th Floor, Zone B, Building 1, 618 Chengliu Middle Road, Jiading District, Shanghai

官方网站: www.qinnav.com

热线: 400-060-8030



©2024, QeeTek Technology Ltd. All rights reserved. QeeTek is the trademark of QeeTek Technology Ltd. registered in People's Republic of China. All other trademarks are the property of their respective owners.